

INSTALLATION INSTRUCTIONS LED TRACK - FLAT BACK

Document:	CI308X81R0	Date:	2013-7-31
Created By:	TMT	DCR#:	2013-205



CAUTIONS

IMPORTANT SAFEGUARDS

When using electrical equipment, basic safety precautions should always be followed including the following:

READ AND FOLLOW ALL SAFETY INSTRUCTIONS

- DANGER**- Risk of shock- Disconnect power before installation.
DANGER – *Risque de choc – Couper l'alimentation avant l'installation.*
- This luminaire must be installed in accordance with the NEC or your local electrical code. If you are not familiar with these codes and requirements, consult a qualified electrician.
Ce produit doit être installé conformément à NEC ou votre code électrique local. Si vous n'êtes pas familier avec ces codes et ces exigences, veuillez contacter un électricien qualifié.
- Min 90°C supply conductors.
Les fils d'alimentation 90°C min.
- Wait until fixture has cooled down before installing or servicing the fixture.
- Please read and understand all instructions thoroughly before installing any part of the Track system.

SAVE THESE INSTRUCTIONS FOR FUTURE REFERENCE

Notes:

- All E-conolight Track sections are manufactured with a Polarity Groove.
- All E-conolight Track fixtures are manufactured with Indicator Arrows designed to point toward the Polarity Groove once installed. See **Figures 1-2**.
- E-conolight Track fixtures are UL® Classified for use with E-conolight E-K1 and E-K2 Series, Ruud T1 and T2 Series, and Juno® (not affiliated with E-conolight or Ruud) T and TU Series track systems only.
- All E-conolight Track fixtures are supplied with a Contact Support to convert fixture from Single Circuit installation to Two Circuit Installation. See **Figure 3**

DIMMING INFORMATION

For a list of approved dimmers visit www.e-conolight.com

FIXTURE INSTALLATION – SINGLE CIRCUIT TRACK

- Insert Brass Contact on top of Track Adapter into the Track Channel. See **Figures 1 and 3**.
- Rotate the Track Adapter 90° so that the Indicator Arrows point toward the Polarity Groove once installed. See **Figure 2**. Pull Adapter Latch down as you rotate Track Adapter in order for Latch to clear track edge and allow it to snap into place in the track.
- To remove or relocate track fixture location, pull Adapter Latch down, rotate the Track Adapter 90° away from the Polarity Groove and remove.

FIXTURE INSTALLATION – TWO CIRCUIT TRACK

- To install track fixture into lower circuit of two-circuit track, follow directions for single circuit installation.
- To install track fixture into upper circuit of two-circuit track, raise the Brass Contact labeled “P” by grasping Contact with needle nose pliers and pulling up into position. See **Figure 3**.
- Insert Contact Support by tipping and positioning it under the “P” Contact. See **Figure 3**. Snap Contact Support in place.
NOTE: Once the contact support is in place, make sure the “P” contact is fully seated in the support by using the needle nose pliers to push the “P” contact into place.
- Refer to instructions 1-3 under “Fixture Installation on Single Circuit Track” section.

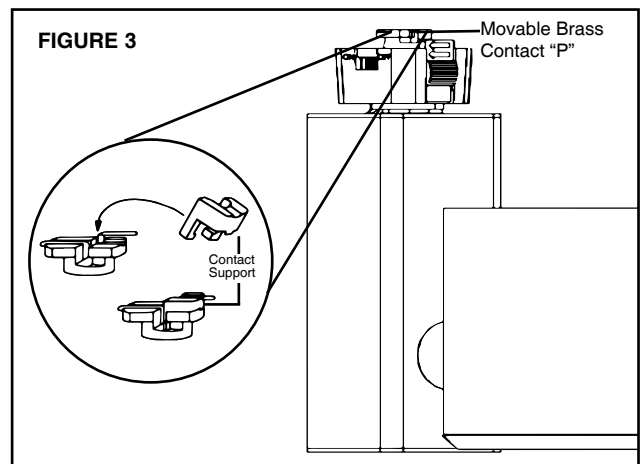
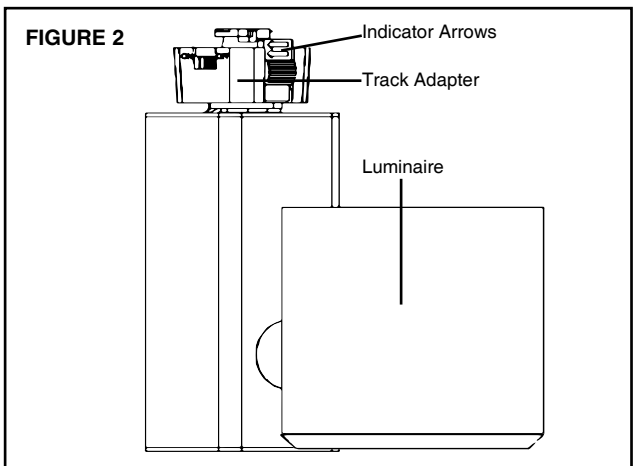
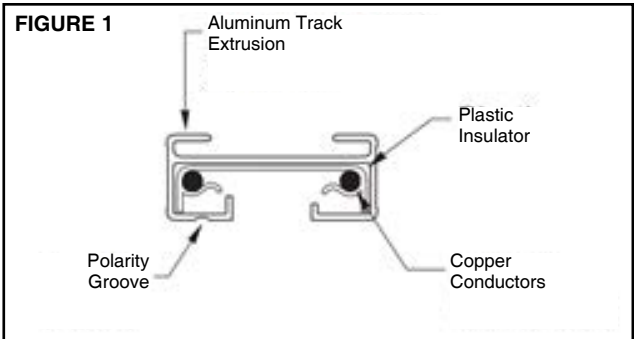

INSTALLATION INSTRUCTIONS LED TRACK - FLAT BACK

Document:	CI308X81R0	Date	2013-7-31
Created By:	TMT	DCR#	2013-205

REFLECTOR REPLACEMENT (FLOOD REFLECTOR INSTALLED)

1. Before attempting Optical Lens Replacement, remove fixture from track.
2. Remove front bezel and reflector. See **Figure 4**.
3. Position LED head facing upward. Insert pins at base of desired reflector into holder socket. **DO NOT** make contact with LED array. See **Figure 5**.
4. Push front bezel back into position. See **Figure 6**.
5. Reinstall fixture onto track.

FIGURE 4

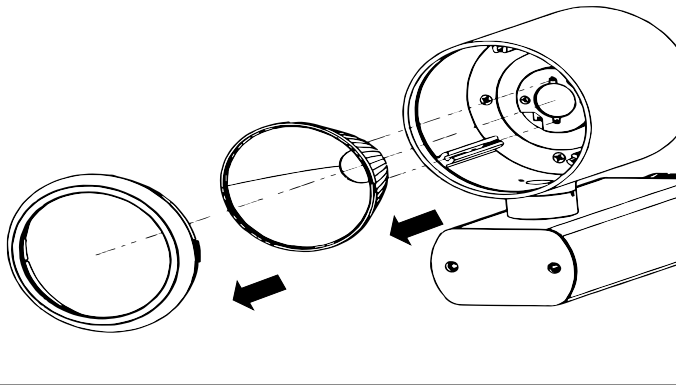

FIGURE 5

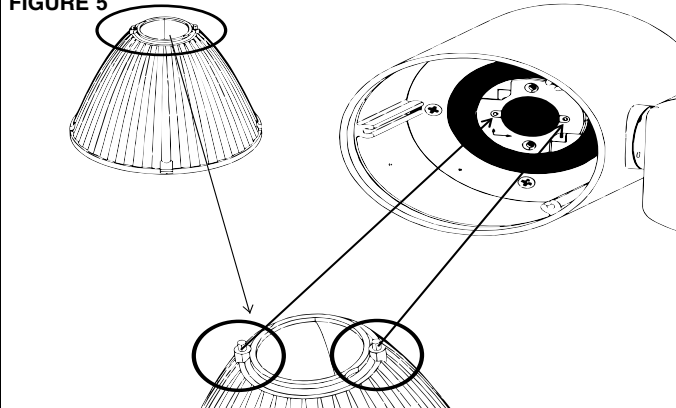

FIGURE 6

