

Instructions for LED Emergency Lighting Fixture

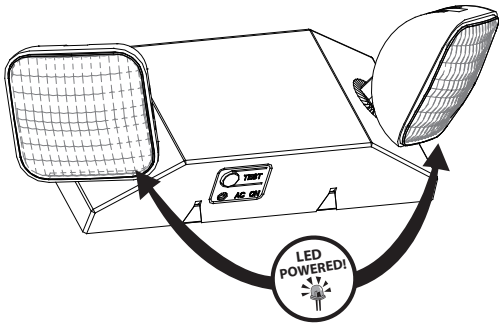

IMPORTANT :

Let the battery charge up for at least 24 hours. Then normal operation of this unit should take effect. To check, press the "TEST" button. The LED lamps on the unit should turn ON. During an electrical power failure, the led lamps will automatically come on for a minimum of 90 minutes. In accordance with NFPA 101, your emergency lighting system must be tested monthly for a minimum of 30 seconds and annually for 90 minutes. Refer to your local codes for any additional requirements that may apply.

IMPORTANT SAFEGUARDS

When using electrical equipment, basic safety precautions should always be followed including the following:

READ AND FOLLOW ALL SAFETY INSTRUCTIONS

1. Do not use outdoors.
2. Equipment should be mounted in locations and at heights where it will not be subject to tampering by unauthorized personnel.
3. Do not mount near gas or electric heaters.
4. The use of accessory equipment not recommended by the manufacturer may cause an unsafe condition.
5. Do not use this equipment for anything other than its intended use.
6. Servicing of this equipment should be performed by qualified personnel.
7. Disconnect AC power before servicing.

SAVE THESE INSTRUCTIONS

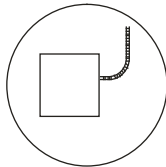
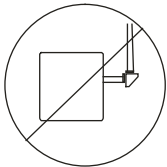

FLEXIBLE CONDUIT ONLY

INSTALLATION (J-BOX MOUNTING)

1. Feed fixture leads through the back plate and connect to AC power supply (Fig A). For 120V use black and white wires and for 277V, use red and white wires.
2. Attach back plate to J-Box and secure with screws.
3. Complete the battery connection. (Fig. B)
4. Align snaps and push housing directly onto the back plate (Fig. C). Apply continuous AC power and press "TEST" button to check light.

INSTALLATION (CONDUIT)

1. Secure back plate to wall surface. Route wires through hole in conduit flange and make conduit connection. For 120V, use black and white wires and for 277V, use red and white wires.
2. Complete the battery connection (Fig. B).
3. Align snaps and push housing directly onto the back plate (Fig. C). Apply continuous AC power and press "TEST" button to check light.

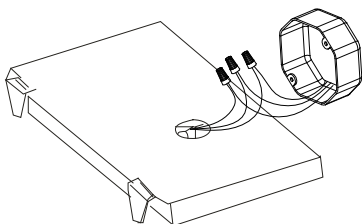

Fig.A (J-Box)

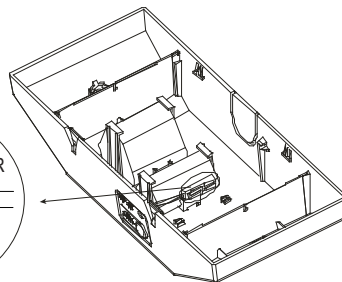
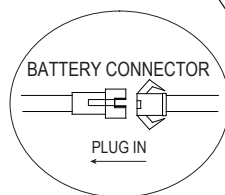

Fig.B

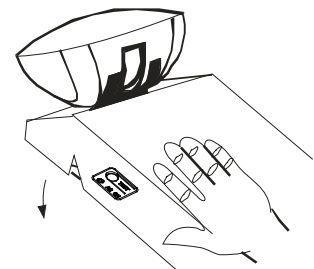

Fig.C

WARNING:

Unused wires must be capped using enclosed wire nuts.

OPERATION

1. During an electrical power failure, the LED lamps will automatically come on for a minimum of 90 minutes.
2. To test, depress the "TEST" switch. The emergency LED lamps will illuminate. When the switch is released, the lamps will go off.

WIRING DIAGRAM

REMOTE CAPABLE

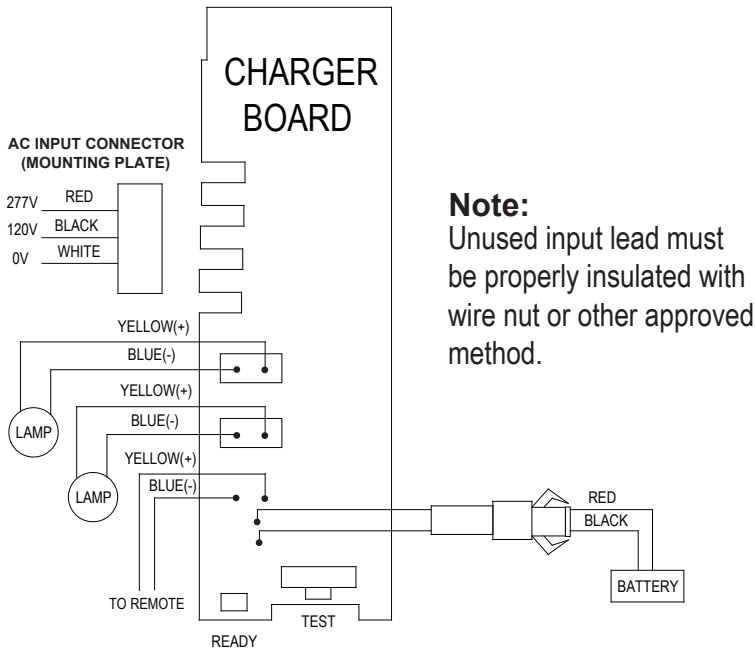

REGULAR

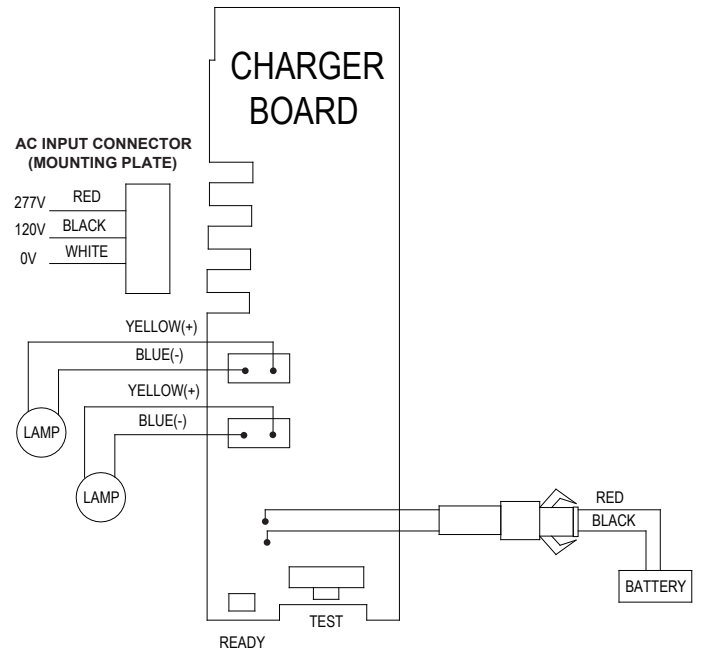

Note:
Use 18-22 AWG stranded wire to connect remote lamp heads.

SELF-DIAGNOSTICS TESTING:

1) Introduction

Once the unit is properly installed according to the Installation instruction sheet and AC power is supplied, the EXIT will come ON. The dual-color LED indicator will also come ON, automatically initiating the self-diagnostic test function. The LED indicator points out the current unit status. A STEADY GREEN on the LED indicator indicates a normal service; BLINKING GREEN indicates that the unit is in testing mode; GREEN/RED FLASHING indicates that the battery is charging; RED (STEADY and BLINKING) would indicate a fault or a service alert. Refer to section 3 – Fault Indication for more details. The LED indicator would be OFF when the unit is in Emergency mode.

2) Self – Diagnostic Service

The self-diagnostic function is factory preset without any field adjustment. The automatic self-diagnostic feature serves the following tests –

- a. On-line real time monitoring of battery and lamps: Identifies battery charging, disconnection and failure along with lamp failure.
- b. Self-testing and a 30-second discharge once every 30 days (conforming to NFPA code requirements), after AC power has been supplied for a minimum of 24 hours.
- c. Self-testing and a 30-minute discharge once every 180 days, after AC power has been supplied for a minimum of 24 hours.
- d. Self-testing and a 90-minute discharge once every 365 days (conforming to NFPA code requirements), after AC power has been supplied for a minimum of 24 hours.

3) Fault Indication

Function	LED Indication
Unit is in normal mode	STEADY Green
Battery Disconnected	STEADY Red
Battery Recharge	Red and Green (flashing alternatively)
Battery Recharge Failure*	FLASHING Red
Battery Failure**	Red BLINKING '2' times
LAMP Failure	Red BLINKING '4' times
Remote LAMP Failure	Red BLINKING '5' times

* A battery recharge failure will come up if the battery is NOT able to recharge within the 24hrs charging time

** A battery failure will come up if the battery is NOT able to operate the lamps for the period of a discharge test

4) Manual Testing

This unit also provides for manual testing by pushing the test switch in a specific pattern. The different patterns and the resulting tests are listed in the table below.

ACTION	REACTION AND LED INDICATION
Push test button once (within 2 seconds)	30-second test; FLASHING Green
Push test button '2' times (within 2 seconds)	30-minute test; Green BLINKING '2' times
Push test button '3' times (within 2 seconds)	90-minute test; Green BLINKING '3' times
Push & Hold test button (3-5 seconds)	System Interruption
Push & Hold test button (more than 6 seconds)	System Reset

5) Operation

During an electrical power failure, the lamps will automatically come ON for a minimum of 90 minutes. To test this unit, the battery needs to be charged initially for 2 hours before depressing the test switch (to do manual test). On pressing the test switch, the Lamps will illuminate. The Lamps will turn OFF after 30-sec /30-min /90-min depending on the number of times the switch has been pressed.