

# E-WW2L Series

LED High-Output Wall Mount  
Replaces 100W PSMH



## Bright Light That Lasts - Up to 172,000 Hours!

This LED Wall Mount delivers over 3000 lumens and is the perfect replacement for your 100W PSMH wall mount fixture.

### Efficient

- Up to 99 lumens per watt
- 65% more lumens than previous models

### Durable

- Heavy-duty polycarbonate housing and prismatic refractor that is built to last

### Recommended Use

- Security
- Pathways
- Perimeter lighting

### Input Voltage

- 120V Operation with built-in photocell

### Certifications



"WARNING - Cancer and Reproductive Harm -  
[www.p65warnings.ca.gov](http://www.p65warnings.ca.gov)"



## E-WW2L Series

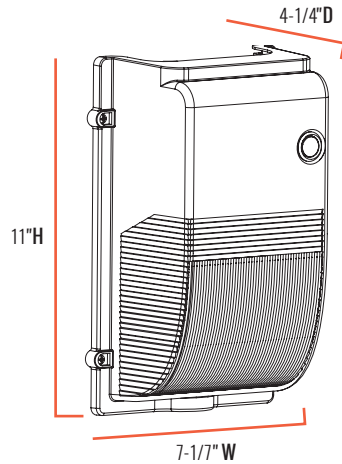

### Series Overview

DIMENSIONS	PRODUCT WEIGHT	MOUNTING HEIGHT	SPACING
4-1/4" D x 7-1/7" W x 11" H	3.5 lbs.	8 to 12 feet	---

### Fixture Specifications

<b>HOUSING</b>	Polycarbonate housing in medium bronze with heavy-duty aluminum mounting plate
<b>LENS ASSEMBLY</b>	UV-stabilized polycarbonate prismatic refractor
<b>MOUNTING</b>	Mounts over a 4' square or octagonal junction box Knockouts provided on back and bottom of housing for 1/2" conduit entry

### Electrical Performance

OPERATING MINIMUM	LIFESPAN <small>L<sub>70</sub> AT 25°C (77°F)</small>	POWER FACTOR	TOTAL HARMONIC DISTORTION	DIMMABLE
-40°C (-40°F)	Estimated 172,000 Hours	> 0.95	< 20%	No
<b>INPUT VOLTAGE</b>	<b>120V</b>	<b>208V</b>	<b>240V</b>	<b>277V</b>
<b>Current Draw (Amps)</b>	0.3A	---	---	---

### Warranty & Certifications

WARRANTY	UL LISTED	DLC	ENERGY STAR
5-Year Limited	Wet Locations	---	---

### CORRELATED COLOR TEMPERATURE (CCT)

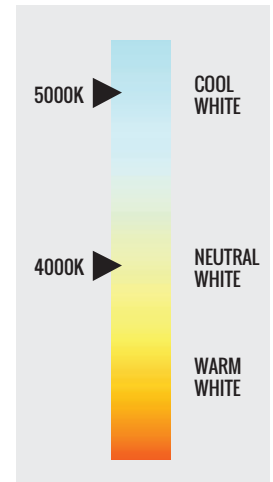

### Output Specifications

SKU	LIGHT OUTPUT	COLOR TEMP <small>(See chart)</small>	POWER CONSUMPTION	COLOR ACCURACY	REPLACES
<b>E-WW2L3UCMP</b>	3580 Lumens	Cool White (5000K)	36W	≥ 70 CRI	100W PSMH
<b>E-WW2L3UNMP</b>	3377 Lumens	Neutral White (4000K)	36W	≥ 70 CRI	100W PSMH